

# AirStar chain hoist

Designed for general commercial applications where variable speed pneumatic power is preferable. Rated for 1/4, 1/2 and 1 ton capacities, this compact, lightweight hoist features:

- Hoist alloy load chain for heavy duty or stainless steel chain for spark resistant, medium duty loads
- Positive action, heavy-duty shoe type brake that holds the load
- Multi-vane rotary air motor for high torque, smooth operation
- Accurately machined heat treated alloy steel spur gears
- Spark resistant models available for hazardous environments
- Pull cord or pendant throttle control available
- Pull cord control hoists provide a lightweight, economical hoist for accurate control of loads
- Optional pendant throttle control hoists offer ergonomic, one-hand control for ease of operation
- Hook or lug suspension available
- Inlet air swivel with built-in strainer provides free hoist movement
- Aluminum frame and end cover contributes to the lightweight, easily portable, and rugged design
- External brake adjustment
- Limit stops prevent over-travel in upper and lowering directions
- Equa-torque gearing of alloy steel, heat treated spur gears are accurately machined to provide a close meshed, compact gear reduction
- Tapped exhaust port 1/2 NPTF... for cleanroom applications or to add a supplemental muffler in addition to the built-in muffler for even quieter operation
- Lifetime warranty
- Metric rated
- Made in U.S.A.



## Basic Hoist Data

**Rated Loads:** 1/4, 1/2 and 1 Ton  
(Spark resistant models are rated at 3/8 and 3/4 ton)

## Air Pressure

**Recommended:** 90 PSI

**Air Consumption:** 48 SCFM at 90 PSI

**Net Wt. (Basic Hoist):** 36 lbs.

**Suspension:** Hook or lug

**Control:** Pull Cord or Pendant Throttle

**Air Inlet:** 3/8 NPTF

**Air Supply Hose:** 1/2 I.D. min.

**Air Exhaust:** 1/2 NPTF

**Lift:** 10 foot lifts are standard. Longer lifts are an optional extra.

## Pendant

**Control:** 6 foot length is standard.

Longer lengths are an optional extra.

**Optional:** For greater corrosion resistance, a plated load chain is offered as an optional extra.

# AirStar with hook suspension-Specifications

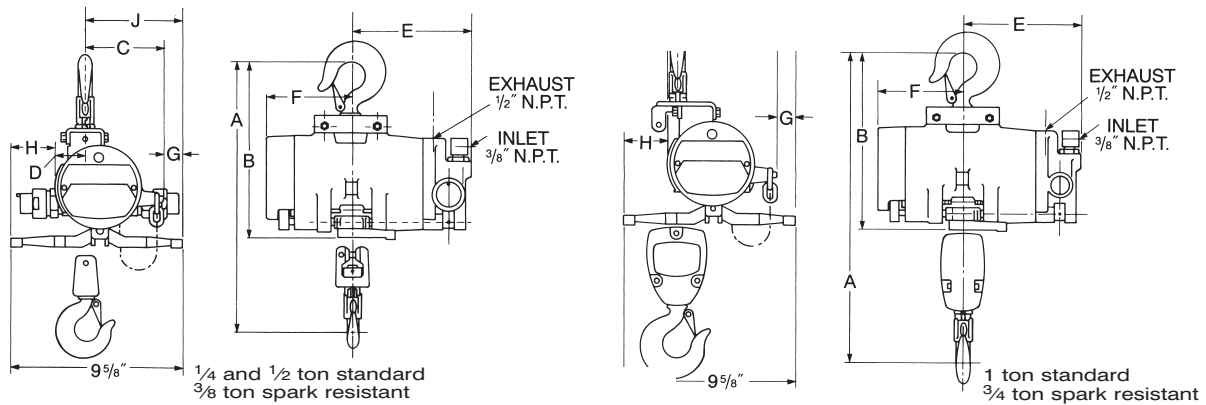

## Clearance dimensions (in.)

Rated capacity* (tons)	Product code	A	B	C	D	E	F	G	H	J
1/4	7400A	15 1/4	10 1/4	4 3/4	1 3/4	7 1/16	5 1/16	15 1/16	2 3/16	5 11/16
1/4	7400B	15 1/4	10 1/4	4 3/4	1 3/4	7 1/16	5 1/16	15 1/16	2 3/16	5 11/16
1/4	7400C	15 1/4	10 1/4	4 3/4	1 3/4	7 1/16	5 1/16	15 1/16	2 3/16	5 11/16
1/4	7400D	15 1/4	10 1/4	4 3/4	1 3/4	7 1/16	5 1/16	15 1/16	2 3/16	5 11/16
1/2	7401A	15 1/4	10 1/4	4 3/4	1 3/4	7 1/16	5 1/16	15 1/16	2 3/16	5 11/16
1/2	7401B	15 1/4	10 1/4	4 3/4	1 3/4	7 1/16	5 1/16	15 1/16	2 3/16	5 11/16
1/2	7401C	15 1/4	10 1/4	4 3/4	1 3/4	7 1/16	5 1/16	15 1/16	2 3/16	5 11/16
1/2	7401D	15 1/4	10 1/4	4 3/4	1 3/4	7 1/16	5 1/16	15 1/16	2 3/16	5 11/16
3/8	7403A	15 1/4	10 1/4	4 3/4	1 3/4	7 1/16	5 1/16	15 1/16	2 3/16	5 11/16
3/8	7403B	15 1/4	10 1/4	4 3/4	1 3/4	7 1/16	5 1/16	15 1/16	2 3/16	5 11/16
1	7402A	18	10 1/4	5 3/4	3/4	7 1/16	5 1/16	15 1/16	2 3/16	6 11/16
1	7402B	18	10 1/4	5 3/4	3/4	7 1/16	5 1/16	15 1/16	2 3/16	6 11/16
1	7402C	18	10 1/4	5 3/4	3/4	7 1/16	5 1/16	15 1/16	2 3/16	6 11/16
1	7402D	18	10 1/4	5 3/4	3/4	7 1/16	5 1/16	15 1/16	2 3/16	6 11/16
3/4	7404A	18	10 1/4	5 3/4	3/4	7 1/16	5 1/16	15 1/16	2 3/16	6 11/16
3/4	7404B	18	10 1/4	5 3/4	3/4	7 1/16	5 1/16	15 1/16	2 3/16	6 11/16

## Specifications

Type	Rated capacity* (tons)	Pull cord control		Pendant throttle control**		Reeving	Lifting speed max.† (F.P.M.)	Lowering speed max.† (F.P.M.)
		Product code no.	Net wt. (lbs.)	Product code no.	Net wt. (lbs.)			
<b>Standard models</b>								
Roller chain	1/4	7400A	37	7400B	47	1	65	95
	1/2	7401A	37	7401B	47	1	45	120
	1	7402A	51	7402B	61	2	23	60
Link chain	1/4	7400C	36	7400D	46	1	65	95
	1/2	7401C	36	7401D	46	1	45	120
	1	7402C	49	7402D	59	2	23	60
<b>Spark resistant models</b>								
Link chain	3/8	7403A	36	7403B	46	1	60	100
	3/4	7404A	49	7404B	59	2	29	52

\*\*Equipped with 6 ft. pendant control.

† Speeds based on 90 PSI line pressure and with full rated hoist load.

Hoist speeds are adjustable and can be reduced to 50% of full rated speed. Shipped from factory with hoisting speed set at maximum rated speed; lowering speed set at reduced speed.

Standard lift 10 feet. Longer lifts available.

# AirStar with lug suspension-Specifications

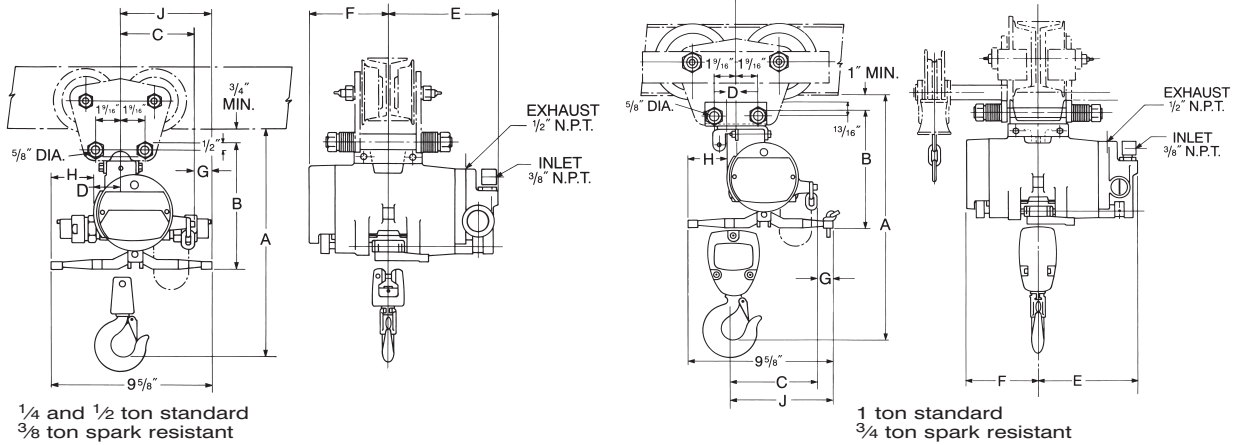

## Clearance dimensions (in.)

Rated capacity* (tons)	Product code	A	B	C	D	E	F	G	H	J
1/4	7400F	13 7/8	8 1/8	4 3/4	1 3/4	7 1/16	5 1/16	15/16	2 3/16	5 11/16
1/4	7400G	13 7/8	8 1/8	4 3/4	1 3/4	7 1/16	5 1/16	15/16	2 3/16	5 11/16
1/2	7401F	13 7/8	8 1/8	4 3/4	1 3/4	7 1/16	5 1/16	15/16	2 3/16	5 11/16
1/2	7401G	13 7/8	8 1/8	4 3/4	1 3/4	7 1/16	5 1/16	15/16	2 3/16	5 11/16
3/8	7403C	13 7/8	8 1/8	4 3/4	1 3/4	7 1/16	5 1/16	15/16	2 3/16	5 11/16
3/8	7403D	13 7/8	8 1/8	4 3/4	1 3/4	7 1/16	5 1/16	15/16	2 3/16	5 11/16
1	7402F	17	8 1/4	5 3/4	3/4	7 1/16	5 1/16	15/16	2 3/16	6 11/16
1	7402G	17	8 1/4	5 3/4	3/4	7 1/16	5 1/16	15/16	2 3/16	6 11/16
3/4	7404C	17	8 1/4	5 3/4	3/4	7 1/16	5 1/16	15/16	2 3/16	6 11/16
3/4	7404D	17	8 1/4	5 3/4	3/4	7 1/16	5 1/16	15/16	2 3/16	6 11/16

## Specifications

Type	Rated capacity* (tons)	Pull cord control		Pendant throttle control**		Reeving	Lifting speed max.† (F.P.M.)	Lowering speed max.† (F.P.M.)
		Product code no.	Net wt. (lbs.)	Product code no.	Net wt. (lbs.)			
<b>Standard models</b>								
Link chain	1/4	7400F	36	7400G	46	1	65	95
	1/2	7401F	36	7401G	46	1	45	120
	1	7402F	49	7402G	59	2	23	60
<b>Spark resistant models</b>								
Link chain	3/8	7403C	36	7403D	46	1	60	100
	3/4	7404C	49	7404D	59	2	29	52

\*\*Equipped with 6 ft. pendant control.

† Speeds based on 90 PSI line pressure and with full rated hoist load.

Hoist speeds are adjustable and can be reduced to 50% of full rated speed. Shipped from factory with hoisting speed set at maximum rated speed; lowering speed set at reduced speed.

Standard lift 10 feet. Longer lifts available.

## Spark Resistant Models

Spark resistant models offer maximum protection in hazardous environments. Components for spark resistance include bronze alloy hooks, stainless steel hook latches, non-magnetic chrome-nickel stainless steel load chain, modified load sprocket, guide and stripper arrangement and lower blocks of stainless steel for the 3/8-ton single line model and anodized aluminum body on the 3/4-ton two part reeved model.

The spark resistant models have capacities derated. The stainless steel load chain is lower strength and not as hard as the standard alloy steel load chain, thereby requiring reduced capacity ratings on these models.

Warning: The equipment illustrated here is not designed or suitable as a power source for lifting or lowering persons. Exceeding rated capacity is dangerous and can result in injury to persons and damage property.